

## Voltage signal measurement with Ib2 mode of UTI

Xiujun Li

Figure 1 shows a simplified circuit diagram for the measurement of the voltage signal with using the Ib2 mode of the UTI.

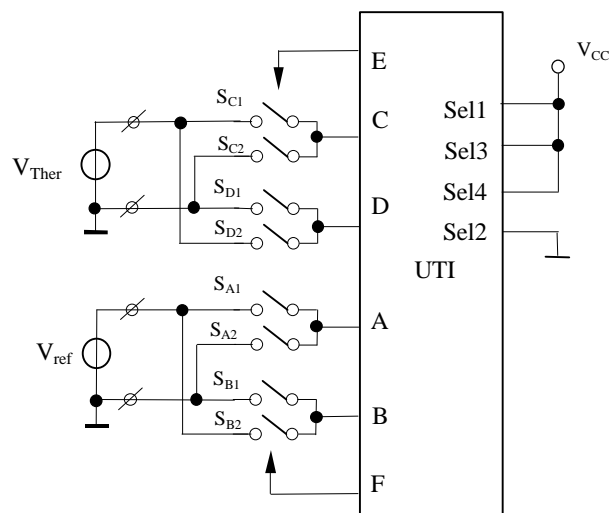

Figure 1 A simplified circuit diagram for the measurement of the voltage signal with using the Ib2 mode of the UTI.

In this Figure,  $V_{Ther}$  and  $V_{ref}$  denote the thermocouple signal and a voltage reference, respectively. The switches  $S_{C1}$ ,  $S_{C2}$ ,  $S_{D1}$ ,  $S_{D2}$ ,  $S_{A1}$ ,  $S_{A2}$ ,  $S_{B1}$  and  $S_{B2}$  form a chopping for the measured signals,  $V_{Ther}$  and  $V_{ref}$ . Where  $S_{C1}$ ,  $S_{D1}$ ,  $S_{A1}$  and  $S_{B1}$  are controlled by the signal from pin E. The switches  $S_{C2}$ ,  $S_{D2}$ ,  $S_{A2}$  and  $S_{B2}$  are controlled by the signal from pin F. The thermocouple voltage signal is obtained from:

$$V_{Ther} = \frac{T_{CD} - T_{off}}{T_{AB} - T_{off}} \cdot V_{ref} \quad (1)$$

The reference voltage should be between 100 mV and 200 mV. With this circuit, the signal  $V_{Ther}$  within a range of  $\pm 200$  mV can be measured accurately. The resolution and accuracy for the voltage signal measurement could be 13 bits and 11 bits, respectively.

The circuit shown in Figure 1 also can measure the signal  $V_{Ther}$  with a common mode DC voltage.

In order to reduce the effect of the lead wire and the switch ON resistor, the analog switch with low leakage current should be used.

Figure 2 shows a circuit diagram with practical components. In this example, a thermocouple with ground is measured.

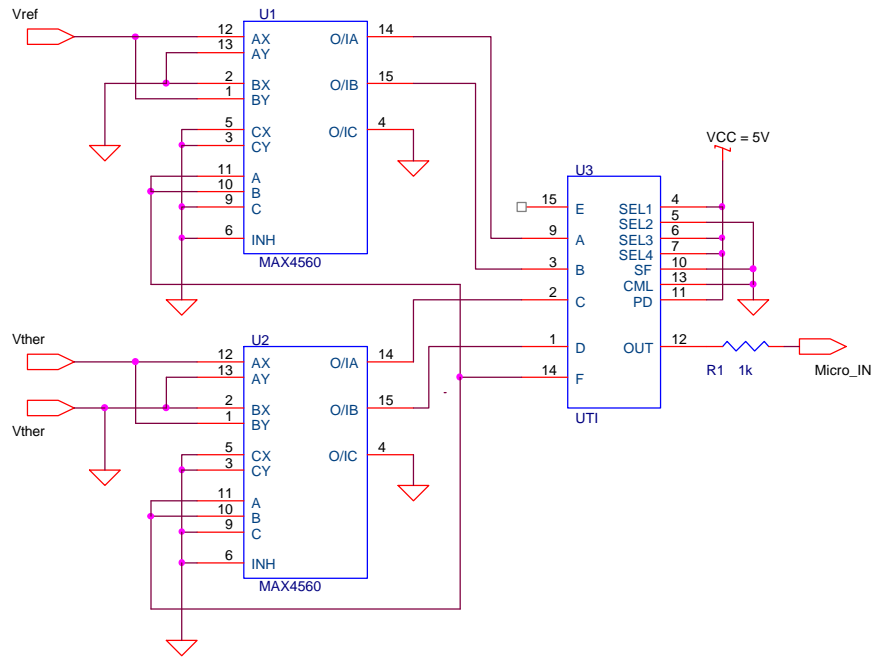

Figure 2 A Circuit diagram with practical components.

Components:

- 1      2 Max4560    MAXIM Multiplexer (or other)
- 2      1 UTI03     Smartec UTI
- 3      Voltage ref    100 – 200 mV ref,

As shown in (1)  $V_{ref}$  must have a good long term stability due to the fact  $V_{ther}$  is given as a fraction of  $V_{ref}$ . This low  $V_{ref}$  can easily be made by a normal bandgap reference and a resistor divider.

Normal precautions have to be taken to the connection of the thermocouple to the multiplexer.